

**MITY STRONG.  
MITY DURABLE.  
MITY MITE.**



**PIPE PULLER  
OWNER'S MANUAL**



## TABLE OF CONTENTS

- About Mity Mite Mfg.
- Put Power into Your Project
- The Puller Line
- Mity Mite Replacement Parts
- Pipe Puller Specifications
- Operating Instructions
- Troubleshooting Chart

## ABOUT MITY MITE

When it comes to construction safety equipment, Mity Mite Manufacturing, an industry leader in pipe puller technology, stands out. Why? Consider the following:

- Mity Mite Manufacturing has been serving the needs of underground contractors and municipalities since 1965.
- Our experienced personnel can quickly and efficiently build and deliver our exclusive pipe pullers.
- Headquartered in Phoenix, Arizona, Mity Mite offers a complete customized line of top-of-the-line pipe pullers and accessories.
- We service the products we sell.
- Mity Mite Manufacturing is a division of Arizona Structure Technologies, Inc.

Mity Mite Manufacturing. When it comes to customers, products and service — we deliver.

## PUT POWER INTO YOUR NEXT PIPELINE PROJECT

Joining one concrete pipe to another used to be time-consuming and expensive. However, Mity Mite Manufacturing has changed all that. Rugged, dependable and compact, Mity Mite makes joining pipe easy and profitable

Patented Mity Mite pullers were developed more than 40 years ago in response to the construction industry's need for a device that could join large sections of concrete pipe, steel pipe, steel cylinder pipe or box culvert — weighing up to 30 tons and measuring as much as 144" in diameter.

The innovative, low-maintenance Mity Mite pipe puller line includes two hydraulic models for use inside pipe, 42" to 144" in diameter.

Our patented line of pipe pullers are the most cost-effective machines available for joining large pipe and box culverts. Designed, manufactured and tested at our fabrication complex in Phoenix, Arizona, Mity Mite pullers are laser compatible, safe, simple to use and run on 12-volt batteries.

And, our complete parts inventory assures your crews of quality, service and parts availability when you need it most.

Get it together; with Mity Mite

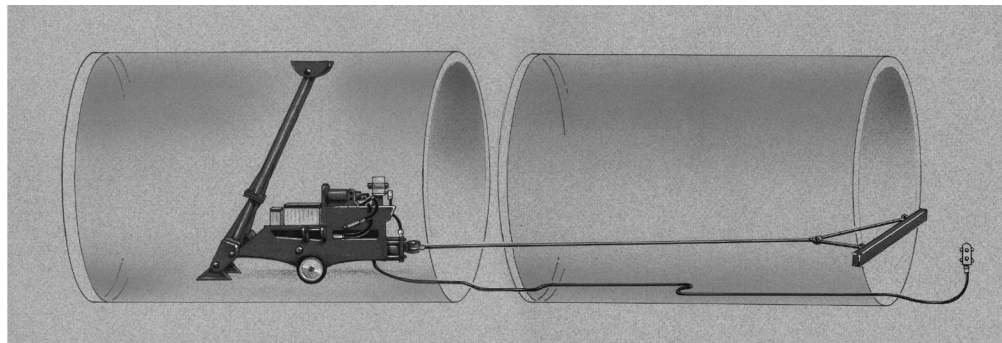

***Tough Mity Mite pipe pullers join a variety of pipe materials and sizes quickly and efficiently.***



1945 W. Broadway  
Phoenix, Arizona 85041  
602.288.1471 [office]  
602.288.1470 [fax]  
www.azst.net

# THE MITY MITE PIPE PULLER LINE

# MITY MITE REPLACEMENT PARTS

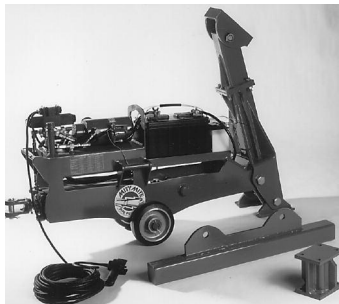

## Model 516

Inside application:  
42"-108"  
15 ton capacity  
300 lbs.  
Remote control  
1" IWRC cable (by others)  
3.5 gallon oil reservoir  
(1) 12 volt battery, group 27 (by others)  
(1) 12 volt motorcycle battery



## Model 5516

Inside application:  
72"-144"  
30 ton capacity  
560 lbs.  
Remote control  
1" IWRC cable (by others)  
7 gallon oil reservoir  
(2) 12 volt batteries, group 27 (by others)  
(1) 12 volt motorcycle battery



MM 0080 Yoke



MM 205 Upper Shoe



MM 504 Subplate Base



MM 113 Lower Shoe

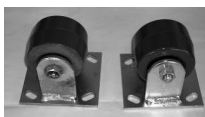

MM 107 HD Front Casters (5516 only)



MM 114 Wheels



MM 115 Parker Hannifin Valve



MM 104 Hydraulic Cylinder



MM 106 Monarch Pump



MM 108 Solenoid



MM 1120 Remote Control Box with Cable



MM 215 12 Volt Motorcycle Battery

# MITY MITE PIPE PULLER SPECIFICATIONS

Model #	Capacity	Weight (lbs.)
516 (42"-108")	15 tons	300
5516 (72"-144")	30 tons	560

## Recommended Pulling Cable Sizes

*Note: Never use chain in place of cable.*

516	1" IWRC
5516	1" IWRC

## Batteries

*All models use one each of these batteries, except model 5516, which uses two Group 27.*

12 volt DC	Group 27
12 volt M3218L	(motorcycle)

We recommend placing batteries on a daily trickle charge for maximum performance.

## Oil Reservoir Capacity:

*Use 10 weight hydraulic oil or power steering fluid. (DO NOT MIX FLUIDS)*

516	3.5 gallons
5516	7 gallons

# OPERATING INSTRUCTIONS

Mity Mite pipe pullers — all you need to increase profits.

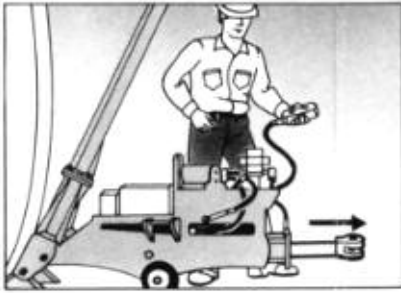

**1** Fully extend the Mity Mite cylinder.

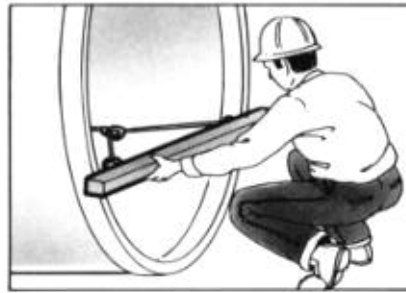

**2** Place pulling bridle on pipe to be pulled.

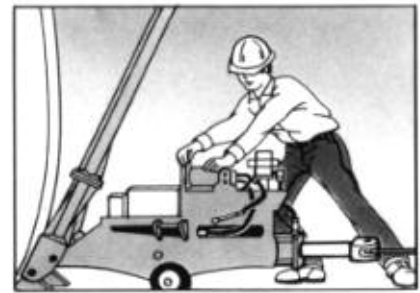

**3** Take up slack on cable by rolling the machine back.\*

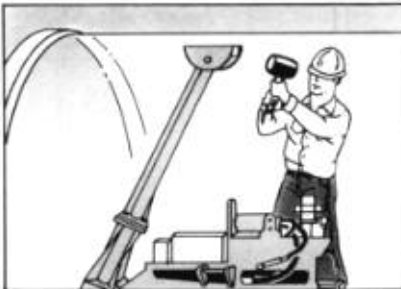

**4** Set the anchor by striking the upper shoe on the front side.

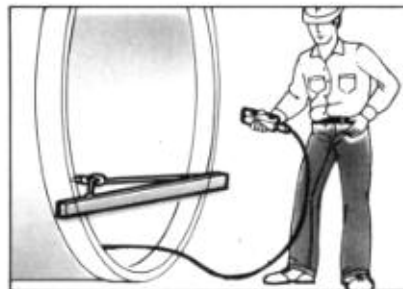

**5** With incoming pipe suspended by crane, actuate the machine from outside the pipe. Pull until desired gap is achieved.



**6** Release anchor by striking the backside of the upper shoe and repeat the pulling process.\*\*

**\*WARNING. Do not use chain.**

**\*\*NOTE: Release tension on puller before moving.**

# MITY MITE PIPE PULLER: TROUBLE SHOOTING CHART

PROBLEM	CHECK
No power	<ul style="list-style-type: none"> <li>• Be sure all batteries are charged</li> <li>• Check battery connections</li> <li>• Check all other electrical connections</li> <li>• Verify wiring is properly connected</li> </ul>
Batteries are charged, but the unit won't start up	<ul style="list-style-type: none"> <li>• Check remote power cord contacts and connections at hydraulic valve</li> <li>• Check remote power cord for cuts from crushing</li> <li>• Check electric solenoid on side of the hydraulic motor</li> <li>• Check electric motor</li> </ul>
Electric motor runs, but cylinder will not actuate; has little power	<ul style="list-style-type: none"> <li>• Check hydraulic oil level, fill as needed</li> <li>• Clean out hydraulic filter screen</li> <li>• Small battery must be charged to a minimum of 10 volts or the solenoid will not actuate</li> </ul>
Pulls very hard but the pipe won't go home	<ul style="list-style-type: none"> <li>• Check to be sure cylinder was fully extended before beginning to pull</li> <li>• Check to see that grading material is not jammed up in the bottom of the joint preventing it from closing</li> <li>• Check to ensure the pipe is suspended when trying to pull into place. <b>DO NOT TRY TO DRAG PIPE!</b></li> <li>• Check pipe for roundness and quality construction</li> <li>• Is the pipe puller properly sized for this job?</li> <li>• Check hydraulic oil level, fill as needed</li> </ul>
The cylinder does not pull in far enough to close the joint properly	<ul style="list-style-type: none"> <li>• Re-position the pipe puller further back into the pipe</li> </ul>
Joint is not pulling "squarely"	<ul style="list-style-type: none"> <li>• Verify that no obstruction, like a rock, is preventing the joint from properly closing</li> <li>• Re-position the pulling bridle higher in the bell, on the side that needs to be pulled further home. Do not place the pulling bridle at more than a 45 degree angle from horizontal</li> </ul>
Rubber "o-ring" joints	<ul style="list-style-type: none"> <li>• Be sure to properly lubricate the rings before trying to pull the joint together</li> </ul>
The pipe joint behind the pipe puller pulled loose	<ul style="list-style-type: none"> <li>• The crane holding the last pipe joint suspended, as this joint is being pulled home, has moved or the line is too far from plumb while the pipe puller moves the pipe into place. If this continues to occur, move the pipe puller one or two more joints back into installed pipe for additional anchorage*</li> </ul>
Pulling cable size * <b>Do not use chain to extend wire rope.</b>	<ul style="list-style-type: none"> <li>• IWRC wire rope</li> <li>• Model 516 &amp; 5516; use minimum 1" IWRC wire rope</li> </ul>

# PIPE PULLER PARTS

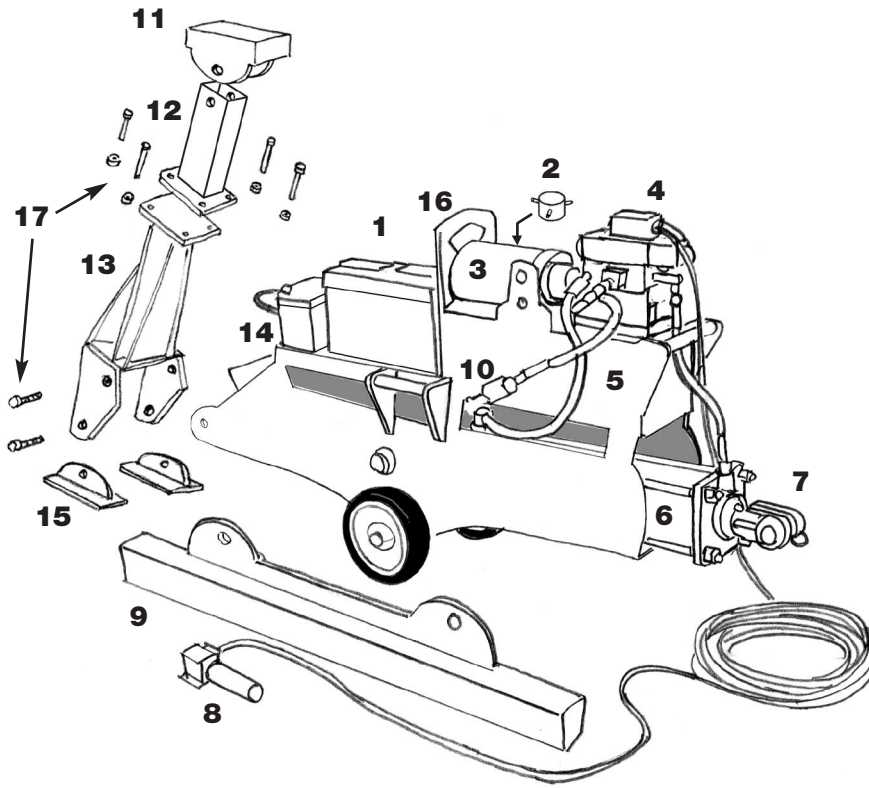

- 1.** Group 27, 12 volt battery
- 2.** Solenoid
- 3.** Hydraulic motor
- 4.** Hydraulic valve
- 5.** Hydraulic oil reservoir
- 6.** Hydraulic cylinder
- 7.** Yoke
- 8.** Remote control & cable
- 9.** Pulling bridle
- 10.** Hydraulic oil screen
- 11.** Upper shoe
- 12.** Upper anchor
- 13.** Lower anchor
- 14.** 12 volt motorcycle battery
- 15.** Lower shoe (2)
- 16.** S/N location: battery side of this plate
- 17.** Anchor bolts (Grade 8):
  - Upper shoe bolt (1) – 1"x 6" bolt & nut
  - Lower shoe bolts (2) – 1'x 3" bolts & nuts
  - Upper/lower anchor bolts (4) – 9/16"x 2" bolts & nuts