

Weld serial number

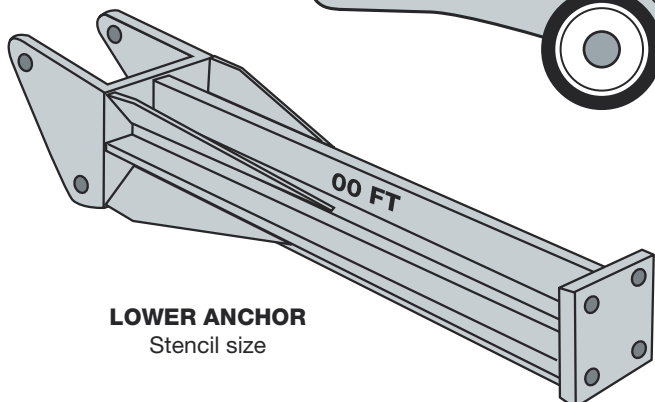

PIPE PULLER

Use existing (round) logo and specification decals and weld serial number in areas indicated



LOWER ANCHOR
Stencil size

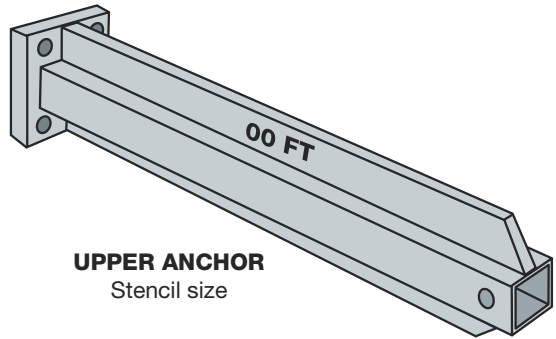

UPPER ANCHOR
Stencil size

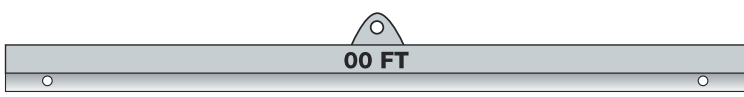

PULLING BRIDLE
Stencil size

PIPE PULLER

Sticker and weld applied by corporate